



## Combined Rubber-Airspring Insulator FAEBI®

for shock and vibration insulation of machines,  
equipment and sub-assemblies

### FAEBI® Product Description

Rubber air-spring for highly, effective insulation of machinery and sub-assemblies against impact and oscillation. The bell-shaped component is made of high-grade elastomer. The construction allows a highly effective insulation without the disadvantage of excessive horizontal deflection. It is impossible for the element to break down as a result of overloading or a sudden drop in pressure. To reduce vertical dampening, the component is available with additional attenuation. The baseplate is equipped with an anti-slip plate so there is no need to anchor the machine to the floor. **Note:** For outdoor use (e.g. isolation of a roof top air condition unit) the FAEBI® can be supplied in **stainless steel** and **EPDM elastomer** version.

#### FAEBI® mechanical-pneumatic control valves (MPN-LCV)

The mechanical-pneumatic relief valves are a simple yet effective solution. The level is constantly scanned by a plunger. The plunger position is transmitted to a slide valve. Depending on the slide valve position, pressure is applied to the air spring or the inside pressure is reduced. The level can be maintained at an accuracy  $\pm 1/10$  mm. Principally three control valves are used. A pressure control valve to limit system pressure to a maximum of 6 bar, water trap to remove vapour and an air filter to remove dust and any foreign bodies from the air supply.

#### Insulation against Impact and Oscillation

Depending upon the static load, the natural frequency of the elements varies between to 3 – 6 Hz in vertical direction. The ratio between vertical and horizontal natural frequency is 1 – 1,5. Maximum spring deflection during impulse load is approximately 15 mm.

#### Range of Application

Excellently suited for active insulation of high-speed power presses, forging hammers as well as other machines and equipment with high dynamic forces. Passive insulation of measuring and testing machines as well as high-precision machine tools.

Systems can also be supplied with an option of electronic or mechanical level control! (See page 21)

#### Assembly

The components are screwed on to the machine by means of pre-drilled holes. It is not necessary to anchor the machine to the floor. The machine is placed on deflated elements which are then inflated to a maximum of 5 – 6 bar via a standard valve. To level the machine, air can either be released or added. The maximum height adjustment available is 10 mm.

#### Control of Air Pressure

Upon request, FAEBI® elements can be equipped with an air pressure monitor. This monitor will indicate if air-pressure goes below the desired value.

FAEBI® 50  
Load (N)

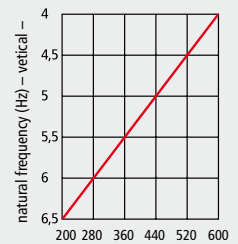

FAEBI® 75  
Load (N)

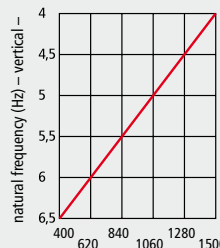

FAEBI® 100  
Load (N)

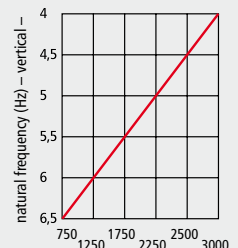

FAEBI® 125  
Load (N)

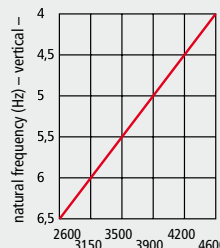

FAEBI® 150  
Load (N)

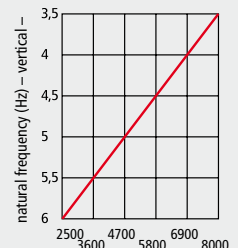

FAEBI® 200  
Load (N)

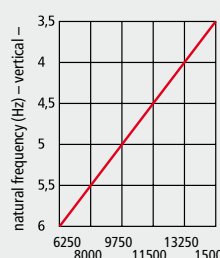

FAEBI® 300  
Load (N)

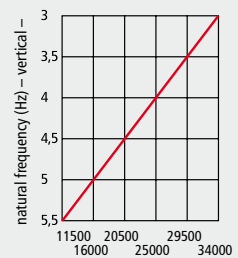

FAEBI® 430  
Load (N)

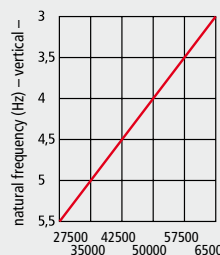

FAEBI® 580  
Load (N)

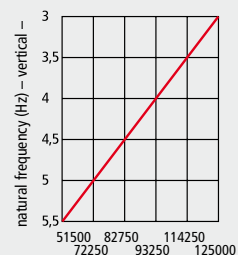

FAEBI® MPN-LCV



Müller-Weingarten punching machine on FAEBI® with level control

**FAEBI® mechanical-pneumatic control valves (MPN-LCV)**

The mechanical-pneumatic relief valves are a simple yet effective solution. The level is constantly scanned by a plunger. The plunger position is transmitted to a slide valve. Depending on the slide valve position, pressure is applied to the air spring or the inside pressure is reduced. The level can be maintained at an accuracy  $\pm 1/10$  mm. Principally three control valves are used. A pressure control valve to limit system pressure to a maximum of 6 bar, water trap to remove vapour and an air filter to remove dust and any foreign bodies from the air supply.

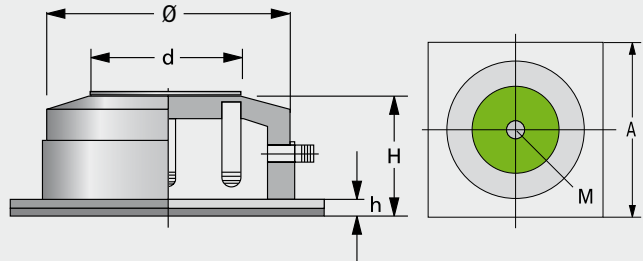

**Important Notice:**

The element must be chosen in such a way as not to exceed the maximum load! Inflation and deflation may be carried out under pressure only! Screw must be screwed in manually – do not use any wrench! Subject to technical changes!

type	load N/pc.	max. pressure/ bar	A mm	Ø mm	H approx. mm = workheight	d mm	h mm	M
FAEBI® 50	200 – 600	3	110	80	60	35	5	M 10
FAEBI® 75	400 – 1500	3	115	97	65	43	5	M 12
FAEBI® 100	750 – 3000	5	135	118	65	60	5	M 12
FAEBI® 125	2600 – 4600	5,5	165	140	90	66	5	M 16
FAEBI® 150	2500 – 8000	6	200	170	90	80	8	M 16
FAEBI® 200	6250 – 15000	6	260	236	90	130	8	M 16
FAEBI® 300	11500 – 34000	6	370	340	90	200	8	M 20
FAEBI® 430	27500 – 65000	6	500	480	90	315	8	M 20
FAEBI® 580	51500 – 125000	6	680	650	99	380	14	M 24

**Protective cup:**

If the machine base does not cover Ø "d" fully we recommend the use our special protective cups.

**FAEBI® in stainless steel and EPDM-version (outdoor application)**

FAEBI® in stainless steel and EPDM-version are especially manufactured for the outdoor application. Machines like air conditioning, compressor, etc can be used outdoors! Price and delivery time upon request.



**Protective cup for FAEBI®-Elements**

Material: St 37-2 (black primed)

type	A mm	Ø mm	S	h mm	d mm
FAEBI® 100	14	140	5	45	2
FAEBI® 125	18	160	5	60	2
FAEBI® 150	18	190	5	60	2
FAEBI® 200	18	255	5	60	3
FAEBI® 300	22	360	5	60	3
FAEBI® 430	22	500	5	60	4
FAEBI® 580	27	680	10	60	4

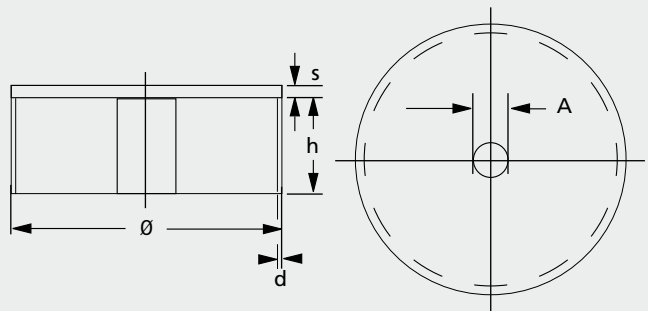

## Combined Rubber-Airspring-Insulator FAEBI® HD with adjustable dampening

for shock and vibration insulation of machines,  
equipment and sub-assemblies



### Combined Rubber-Airspring-Insulator FAEBI®-HD with adjustable dampening

Rubber air-spring insulator FAEBI®-HD is made of a combination of high-grade elastomer and metal with an enlarged sidewall. In order to obtain as high a dampening effect as possible, the air space is split into two chambers (load / dampening volume) linked by an air pipe. By the adjustable valve the dampening can be changed easily from outside. Due to the friction caused by the air-stream passing through the bypass valve, it is possible to adapt the dampening to each application.

Because of the very high dampening, the resonance amplitude is much smaller and therefore you are able to achieve less machine movement. (see graph 1a + 1b) Furthermore the increased transformable energy takes effect on the production quality of your machinery.

#### Note:

In contrast to viscous dampers, the air dampening is absolutely wear-resistant and free of maintenance. Furthermore it is possible to change the dampening from outside.

### Optional: FAEBI® mechanical-pneumatic control valves (MPN-LCV)

The mechanical-pneumatic relief valves are a simple yet effective solution. The level is constantly scanned by a plunger. The plunger position is transmitted to a slide valve. Depending on the slide valve position, pressure is applied to the air spring or the inside pressure is reduced. The level can be maintained at an accuracy  $\pm 1/10$  mm.

Principally three control valves are used. A pressure control valve to limit system pressure to a maximum of 6 bar, water trap to remove vapour and an air filter to remove dust and any foreign bodies from the air supply.



LCV-valve  $\pm 1/10$  mm



PVM-valve  $\pm 1/100$  mm

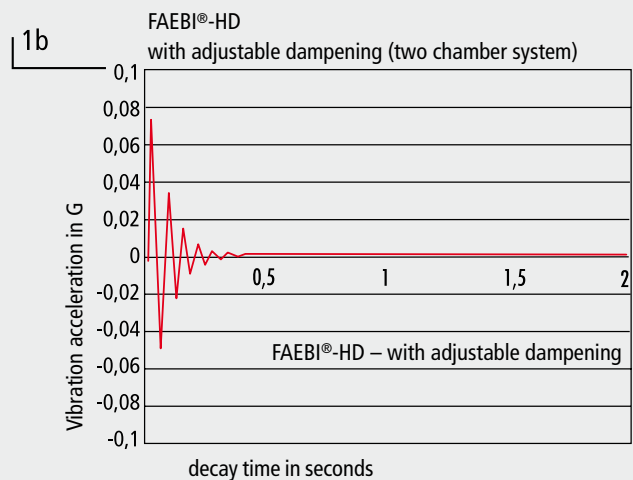
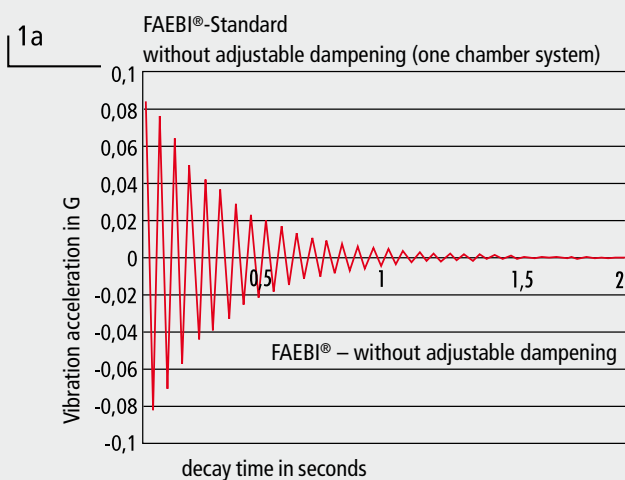



TRUMPF TruPunch 1000 mounted on FAEBI®-HD

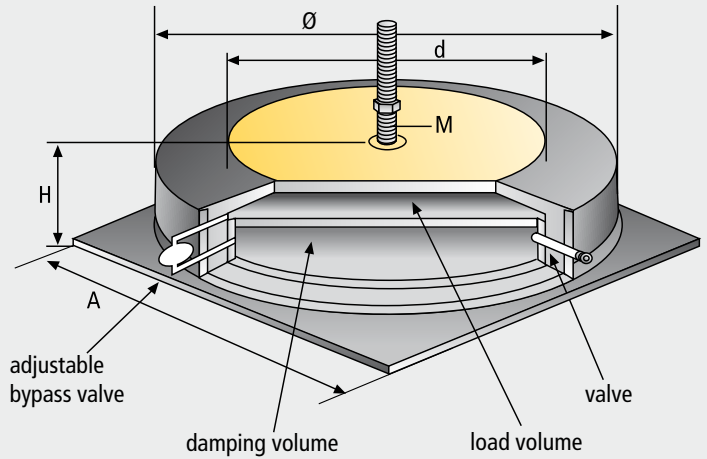

type	load N/pc.	max. pressure / bar	A mm	Ø mm	H approx. mm = workheight	d mm	M
FAEBI® 200-HD	6250 – 15000	6	260	236	90	130	M 16
FAEBI® 300-HD	11500 – 34000	6	370	340	90	200	M 20
FAEBI® 430-HD	27500 – 65000	6	500	480	90	315	M 20
FAEBI® 580-HD	51500 – 125000	6	680	650	125	380	M 24

