

HG+ – New hollow shaft precision



The successor to our versatile hypoid gearhead with hollow shaft on one/both sides.

With the HG+, low torsional backlash and high torsional rigidity assure maximum positioning accuracy of your drives and precision of your machines – even during highly dynamic operation.

Quick size selection

HG+ (example for $i = 5$)
For applications in cyclic operation ($ED \leq 60\%$)

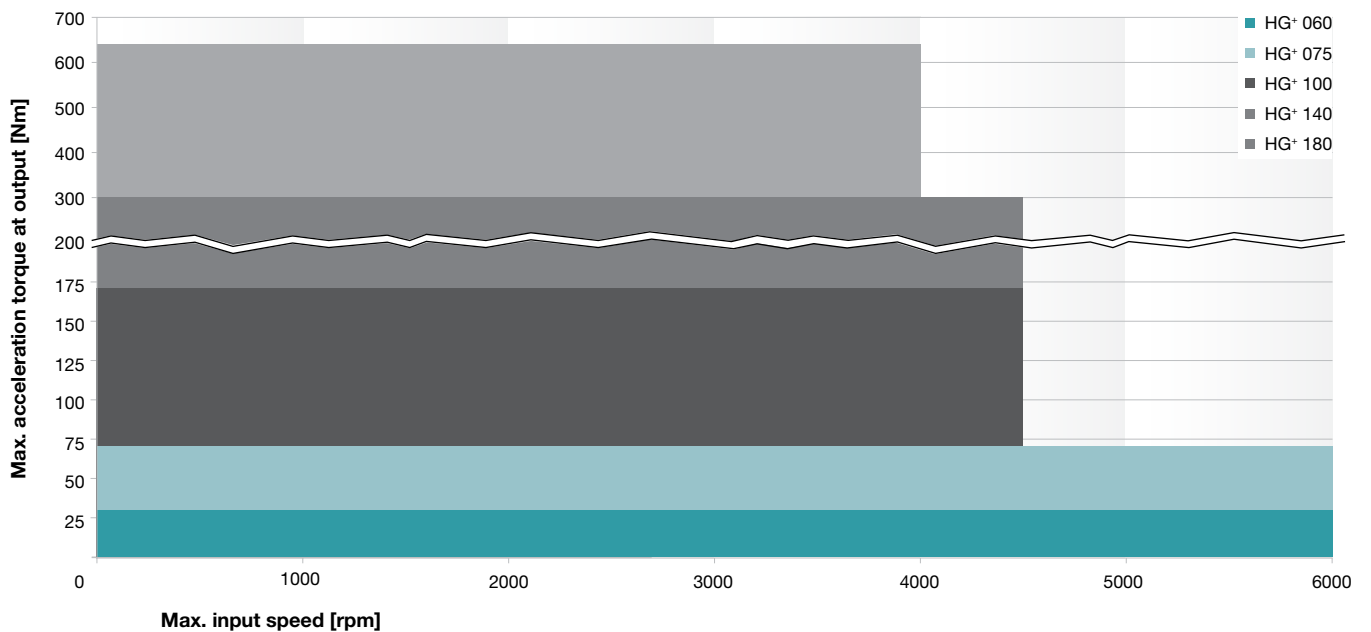

Versions and Applications

HG+

- Cyclic applications
- Reverse operation
- Highly dynamic applications
- High positioning accuracy
- Hollow shaft version

Comparison

Features		HG+ Catalog page 240
Ratios ^{c)}		3 – 100
Torsional backlash [arcmin] ^{c)}	Standard	≤ 4
	Reduced	-
Output type		
Smooth output shaft, rear side		•
Keywayed output shaft, rear side		•
Hollow shaft interface Connected via shrink disc		•
Hollow shaft interface, rear side Connected via shrink disc		•
Closed cover, rear side		•
Input type		
Motor mounted version		•
Type		
ATEX ^{a)}		•
Food-grade lubrication ^{a) b)}		•
Corrosion resistant ^{a) b)}		•
Accessories		
Coupling		•
Shrink disc		•
torqXis sensor flange		•
Intermediate plate for cooling connection		•

^{a)} Power reduction: technical data available upon request ^{b)} Please contact WITTENSTEIN alpha ^{c)} In relation to reference sizes



HG+ 060 MF 1/2-stage

		1-stage					2-stage											
Ratio ^{a)}	<i>i</i>	3	4	5	7	10	12	16	20	25	28	35	40	50	70	100		
Max. acceleration torque (max. 1000 cycles per hour)	T_{2B}	Nm	30	30	30	25	20	30	30	30	30	30	30	30	25	20		
		in.lb	266	266	266	221	177	266	266	266	266	266	266	266	266	221	177	
Nominal output torque (with n_m)	T_{2N}	Nm	22	22	22	20	15	22	22	22	22	22	22	22	20	15		
		in.lb	195	195	195	177	133	195	195	195	195	195	195	195	195	177	133	
Emergency stop torque (permitted 1000 times during the service life of the gearhead)	T_{2Not}	Nm	40	50	50	45	40	50	50	50	50	50	50	50	45	40		
		in.lb	354	443	443	398	354	443	443	443	443	443	443	443	443	398	354	
Nominal input speed (with T_{2N} and 20°C ambient temperature) ^{b), c)}	n_{1N}	rpm	2500	2700	3000	3000	3000	4400	4400	4400	4400	4400	4400	4800	5500	5500		
Max. continuous speed (with 20% T_{2N} and 20°C ambient temperature)	n_{1Ncym}	rpm	3000	3500	4000	3500	3500	5000	5000	5000	5000	5000	5000	5000	5500	5500		
Max. input speed	n_{1Max}	rpm	6000	6000	6000	6000	6000	6000	6000	6000	6000	6000	6000	6000	6000	6000		
Mean no load running torque (with $n_1=3000$ rpm and 20°C gearhead temperature) ^{d)}	$T_{01/2}$	Nm	1.3	1.2	1.1	1.3	1.2	0.2	0.2	0.2	0.2	0.2	0.2	0.1	0.1	0.1		
		in.lb	11.5	10.6	9.7	11.5	10.6	1.8	1.8	1.8	1.8	1.8	1.8	0.9	0.9	0.9		
Max. torsional backlash	j_t	arcmin	≤ 5															
Torsional rigidity	C_{t21}	Nm/arcmin	2.2	2.3	2.4	2.2	1.9	2.3	2.3	2.3	2.3	2.3	2.3	2.3	2.4	2.2	1.9	
		in.lb/arcmin	19	20	21	19	17	20	20	20	20	20	20	20	21	19	17	
Max. axial force ^{e)}	F_{2AMax}	N	2400															
		lb _f	540															
Max. radial force ^{e)}	F_{2RMax}	N	2700															
		lb _f	608															
Max. tilting moment	M_{2KMMax}	Nm	251															
		in.lb	2220															
Efficiency at full load	η	%	96					94										
Service life (For calculation, see the Chapter "Information")	L_h	h	> 20000															
Weight incl. standard adapter plate	<i>m</i>	kg	2.9					3.2										
		lb _m	6.4					7.1										
Operating noise (with $n_1=3000$ rpm no load)	L_{PA}	dB(A)	≤ 64															
Max. permitted housing temperature		°C	+90															
		F	194															
Ambient temperature		°C	0 to +40															
		F	32 to 104															
Lubrication			Lubricated for life															
Paint			Blue RAL 5002															
Direction of rotation			Motor and gearhead opposite directions															
Protection class			IP 65															
Moment of inertia (relates to the drive) Clamping hub diameter [mm]	B	11	J_t	kgcm ²	-	-	-	-	-	0.09	0.09	0.07	0.07	0.06	0.06	0.06	0.06	
				10 ⁻³ in.lb.s ²	-	-	-	-	-	0.08	0.08	0.07	0.06	0.06	0.06	0.05	0.05	0.05
	C	14	J_t	kgcm ²	0.52	0.44	0.40	0.36	0.34	0.20	0.20	0.19	0.19	0.18	0.18	0.17	0.17	0.17
				10 ⁻³ in.lb.s ²	0.46	0.39	0.35	0.32	0.30	0.18	0.18	0.17	0.16	0.16	0.16	0.15	0.15	0.15
E	19	J_t	kgcm ²	0.87	0.79	0.75	0.71	0.70	-	-	-	-	-	-	-	-		
			10 ⁻³ in.lb.s ²	0.77	0.70	0.66	0.63	0.62	-	-	-	-	-	-	-	-		

Please contact us for information on the best configuration for S1 conditions of use (continuous operation).

- ^{a)} Other ratios available on request
- ^{b)} Higher speeds are possible if the nominal torque is reduced
- ^{c)} For higher ambient temperatures, please reduce input speed
- ^{d)} Idling torques decrease during operation
- ^{e)} Refers to center of the output shaft or flange

All technical data for front output side applies.
Technical data for rearward output versions, see page 386.

View A

1-stage:

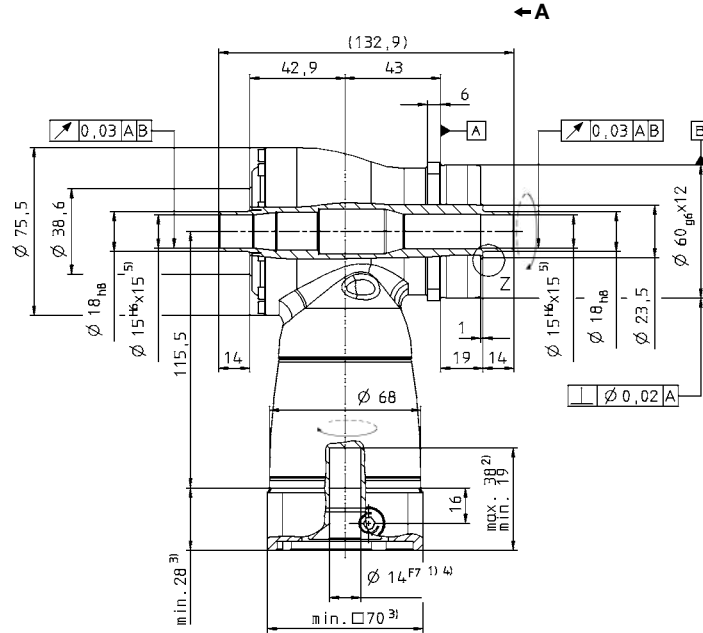
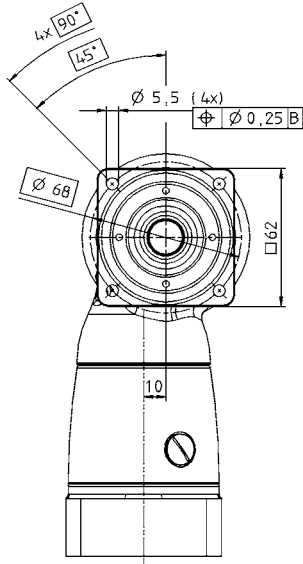

2-stage:

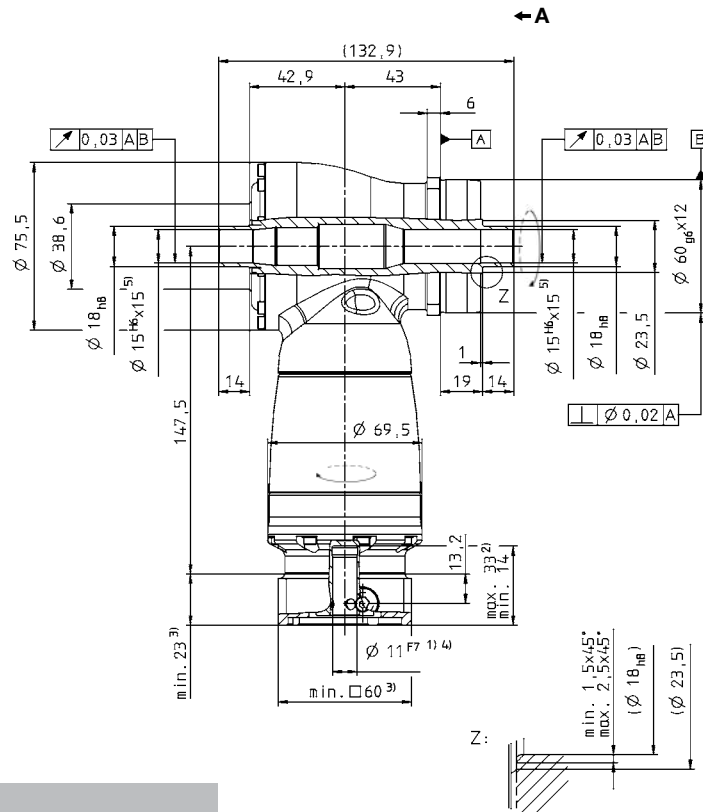
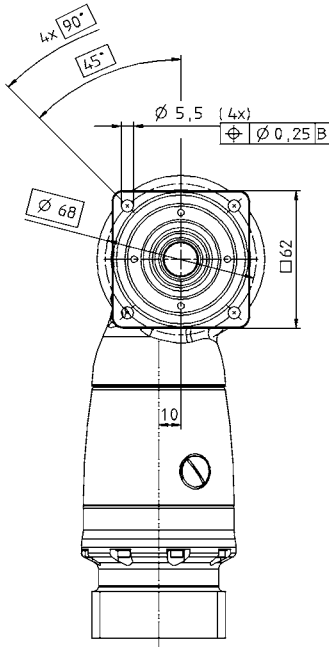

Alternatives: Single output shaft

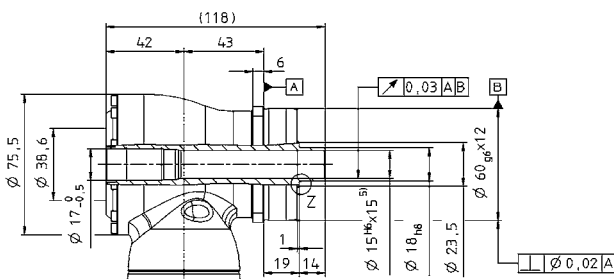

See technical data sheet for available clamping hub diameters (mass moment of inertia). Dimensions available on request.

Non-tolerated dimensions ± 1 mm

- 1) Check motor shaft fit.
- 2) Min./Max. permissible motor shaft length. Longer motor shafts are adaptable, please contact us.
- 3) The dimensions depend on the motor.
- 4) Smaller motor shaft diameter is compensated by a bushing with a minimum thickness of 1 mm.
- 5) Tolerance h6 for mounted shaft.

CAD data is available under www.wittenstein-alpha.com

Motor mounting according to operating manual

Right-angle gearheads
High End

HG+

HG+ 075 MF 1/2-stage

		1-stage					2-stage													
Ratio ^{a)}	<i>i</i>	3	4	5	7	10	12	16	20	25	28	35	40	50	70	100				
Max. acceleration torque (max. 1000 cycles per hour)	T_{2B}	Nm	70	70	70	60	50	70	70	70	70	70	70	70	60	50				
		in.lb	620	620	620	531	443	620	620	620	620	620	620	620	620	531	443			
Nominal output torque (with n_m)	T_{2N}	Nm	50	50	50	45	40	50	50	50	50	50	50	50	45	40				
		in.lb	443	443	443	398	354	443	443	443	443	443	443	443	443	398	354			
Emergency stop torque (permitted 1000 times during the service life of the gearhead)	T_{2Not}	Nm	95	115	115	110	100	115	115	115	115	115	115	115	110	100				
		in.lb	841	1018	1018	974	885	1018	1018	1018	1018	1018	1018	1018	1018	974	885			
Nominal input speed (with T_{2N} and 20°C ambient temperature) ^{b), c)}	n_{1N}	rpm	2300	2500	2800	2800	2800	3500	3500	3500	3500	3500	3500	3500	3800	4500				
Max. continuous speed (with 207% T_{2N} and 20°C ambient temperature)	n_{1Ncym}	rpm	3000	3500	4000	3500	3500	4500	4500	4500	4500	4500	4500	4500	4500	4500				
Max. input speed	n_{1Max}	rpm	6000	6000	6000	6000	6000	6000	6000	6000	6000	6000	6000	6000	6000	6000				
Mean no load running torque (with $n_1=3000$ rpm and 20°C gearhead temperature) ^{d)}	$T_{0/2}$	Nm	2.2	1.9	1.7	2.2	2.0	0.3	0.3	0.2	0.2	0.2	0.2	0.1	0.1	0.1				
		in.lb	19	17	15	19	18	2.7	2.7	1.8	1.8	1.8	1.8	0.9	0.9	0.9				
Max. torsional backlash	j_t	arcmin	≤ 4																	
Torsional rigidity	C_{t21}	Nm/arcmin	5.3	5.9	6.7	6.6	6.5	5.9	5.9	5.9	5.9	5.9	5.9	5.9	6.7	6.6	6.5			
		in.lb/arcmin	47	52	60	58	57	52	52	52	52	52	52	52	59	58	58			
Max. axial force ^{e)}	F_{2AMax}	N	3400																	
		lb _f	765																	
Max. radial force ^{e)}	F_{2RMax}	N	4000																	
		lb _f	900																	
Max. tilting moment	M_{2KMax}	Nm	437																	
		in.lb	3867																	
Efficiency at full load	η	%	96					94												
Service life (For calculation, see the Chapter "Information")	L_h	h	> 20000																	
Weight incl. standard adapter plate	<i>m</i>	kg	4.8					5.1												
		lb _m	10.6					11.3												
Operating noise (with $n_1=3000$ rpm no load)	L_{PA}	dB(A)	≤ 66																	
Max. permitted housing temperature		°C	+90																	
		F	194																	
Ambient temperature		°C	0 to +40																	
		F	32 to 104																	
Lubrication			Lubricated for life																	
Paint			Blue RAL 5002																	
Direction of rotation			Motor and gearhead opposite directions																	
Protection class			IP 65																	
Moment of inertia (relates to the drive) Clamping hub diameter [mm]	C	14	J_t	kgcm ²	-	-	-	-	-	0.28	0.27	0.23	0.23	0.20	0.20	0.18	0.18	0.18	0.18	
				10 ⁻³ in.lb.s ²	-	-	-	-	-	0.25	0.24	0.21	0.20	0.18	0.18	0.16	0.16	0.16	0.16	
	E	19	J_t	kgcm ²	1.46	1.19	1.06	0.95	0.90	0.73	0.71	0.68	0.67	0.63	0.62	0.63	0.63	0.63	0.63	0.63
				10 ⁻³ in.lb.s ²	1.29	1.05	0.94	0.84	0.79	0.64	0.63	0.60	0.59	0.55	0.55	0.55	0.56	0.55	0.55	0.55
H	28	J_t	kgcm ²	2.86	2.60	2.47	2.36	2.31	-	-	-	-	-	-	-	-	-	-		
			10 ⁻³ in.lb.s ²	2.53	2.30	2.19	2.09	2.04	-	-	-	-	-	-	-	-	-	-		

Please contact us for information on the best configuration for S1 conditions of use (continuous operation).

- ^{a)} Other ratios available on request
- ^{b)} Higher speeds are possible if the nominal torque is reduced
- ^{c)} For higher ambient temperatures, please reduce input speed
- ^{d)} Idling torques decrease during operation
- ^{e)} Refers to center of the output shaft or flange

All technical data for front output side applies.
Technical data for rearward output versions, see page 386.

View A

1-stage:

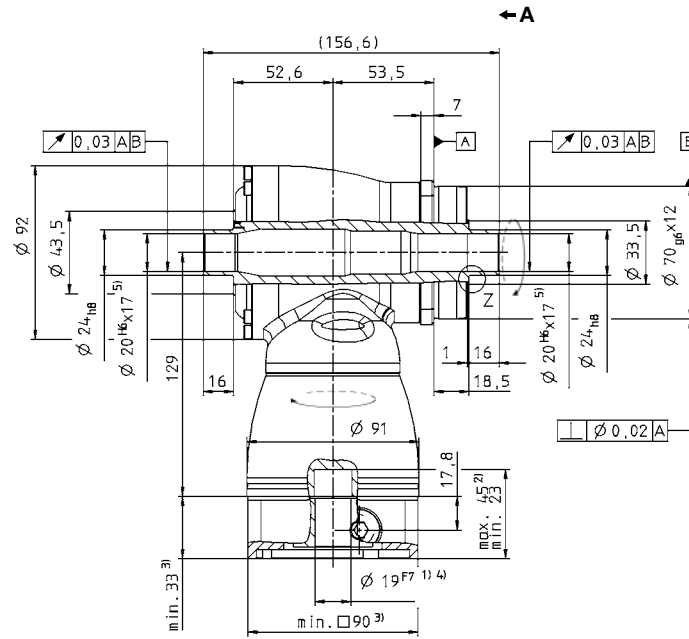
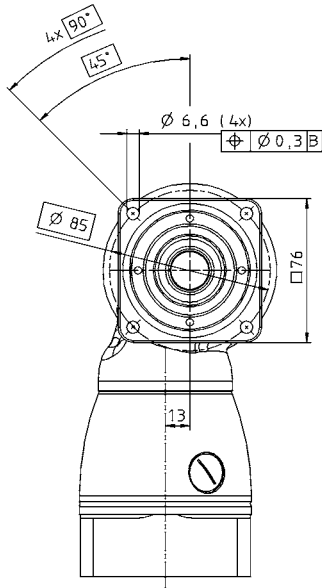

2-stage:

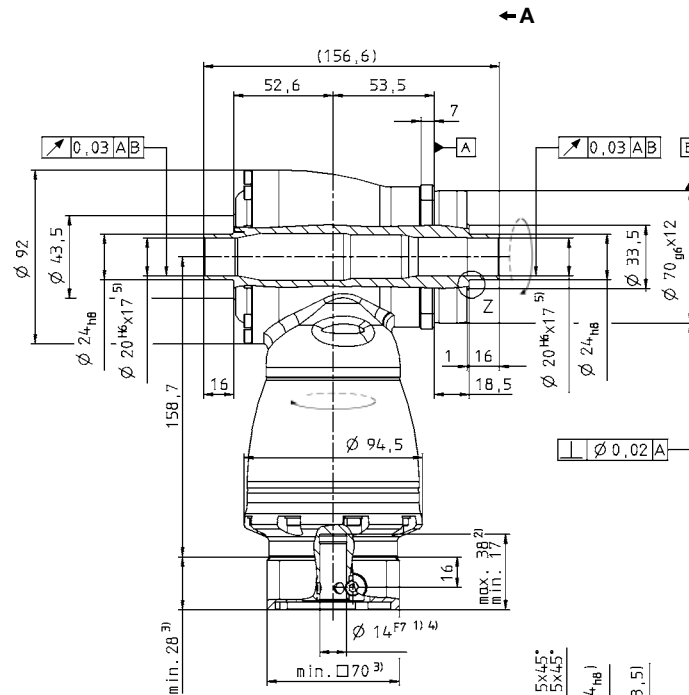
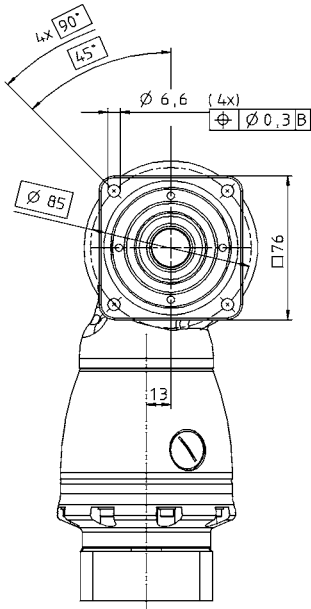

Z:

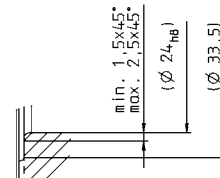

Alternatives: Single output shaft

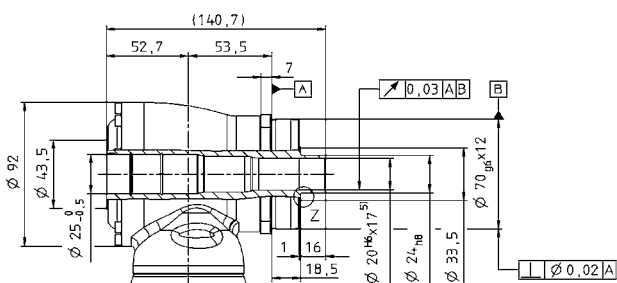

See technical data sheet for available clamping hub diameters (mass moment of inertia). Dimensions available on request.

Non-tolerated dimensions ± 1 mm

- 1) Check motor shaft fit.
- 2) Min./Max. permissible motor shaft length. Longer motor shafts are adaptable, please contact us.
- 3) The dimensions depend on the motor.
- 4) Smaller motor shaft diameter is compensated by a bushing with a minimum thickness of 1 mm.
- 5) Tolerance h6 for mounted shaft.

CAD data is available under www.wittenstein-alpha.com

Motor mounting according to operating manual

HG+ 100 MF 1/2-stage

		1-stage					2-stage													
Ratio ^{a)}	<i>i</i>	3	4	5	7	10	12	16	20	25	28	35	40	50	70	100				
Max. acceleration torque (max. 1000 cycles per hour)	T_{2B}	Nm	170	170	170	145	125	170	170	170	170	170	170	170	170	145	125			
		in.lb	1505	1505	1505	1283	1106	1505	1505	1505	1505	1505	1505	1505	1505	1283	1106			
Nominal output torque (with n_{1N})	T_{2N}	Nm	100	100	100	90	80	100	100	100	100	100	100	100	100	90	80			
		in.lb	885	885	885	797	708	885	885	885	885	885	885	885	885	797	708			
Emergency stop torque (permitted 1000 times during the service life of the gearhead)	T_{2Not}	Nm	220	260	260	255	250	260	260	260	260	260	260	260	260	255	250			
		in.lb	1947	2301	2301	2257	2213	2301	2301	2301	2301	2301	2301	2301	2301	2257	2213			
Nominal input speed (with T_{2N} and 20°C ambient temperature) ^{b), c)}	n_{1N}	rpm	2200	2400	2700	2500	2500	3100	3100	3100	3100	3100	3100	3100	3500	4200	4200			
Max. continuous speed (with 20% T_{2N} and 20°C ambient temperature)	n_{1Ncym}	rpm	3000	3400	3800	3400	3400	4000	4000	4000	4000	4000	4000	4000	4000	4200	4200			
Max. input speed	n_{1Max}	rpm	4500	4500	4500	4500	4500	4500	4500	4500	4500	4500	4500	4500	4500	4500	4500			
Mean no load running torque (with $n_1=3000$ rpm and 20°C gearhead temperature) ^{d)}	$T_{0/2}$	Nm	4.2	3.3	2.5	3.9	3.1	0.7	0.7	0.6	0.4	0.4	0.3	0.2	0.2	0.2	0.2			
		in.lb	37	29	22	35	27	6.2	6.2	5.3	3.5	3.5	2.7	1.8	1.8	1.8	1.8			
Max. torsional backlash	j_t	arcmin	≤ 4																	
Torsional rigidity	C_{t21}	Nm/arcmin	10.7	12.1	14.0	14.2	14.4	12.1	12.1	12.1	12.1	12.1	12.1	12.1	14.0	14.2	14.4			
		in.lb/arcmin	95	107	124	126	127	107	107	107	107	107	107	107	124	126	127			
Max. axial force ^{e)}	F_{2AMax}	N	5700																	
		lb _f	1283																	
Max. radial force ^{e)}	F_{2RMMax}	N	6300																	
		lb _f	1418																	
Max. tilting moment	M_{2KMMax}	Nm	833																	
		in.lb	7370																	
Efficiency at full load	η	%	96					94												
Service life (For calculation, see the Chapter "Information")	L_h	h	> 20000																	
Weight incl. standard adapter plate	<i>m</i>	kg	9.3					9.5												
		lb _m	21					21												
Operating noise (with $n_1=3000$ rpm no load)	L_{PA}	dB(A)	≤ 66																	
Max. permitted housing temperature		°C	+90																	
		F	194																	
Ambient temperature		°C	0 to +40																	
		F	32 to 104																	
Lubrication			Lubricated for life																	
Paint			Blue RAL 5002																	
Direction of rotation			Motor and gearhead opposite directions																	
Protection class			IP 65																	
Moment of inertia (relates to the drive) Clamping hub diameter [mm]	E	19	J_t	kgcm ²	-	-	-	-	-	1.02	0.97	0.86	0.84	0.75	0.74	0.69	0.69	0.68	0.68	
				10 ⁻³ in.lb.s ²	-	-	-	-	-	0.91	0.86	0.76	0.74	0.66	0.66	0.61	0.61	0.60	0.60	
	G	24	J_t	kgcm ²	-	-	-	-	-	2.59	2.54	2.42	2.40	2.31	2.30	2.26	2.25	2.25	2.25	2.25
				10 ⁻³ in.lb.s ²	-	-	-	-	-	2.29	2.25	2.14	2.13	2.05	2.04	2.00	1.99	1.99	1.99	
	H	28	J_t	kgcm ²	4.64	3.80	3.34	2.98	2.79	-	-	-	-	-	-	-	-	-	-	-
				10 ⁻³ in.lb.s ²	4.10	3.36	2.95	2.64	2.47	-	-	-	-	-	-	-	-	-	-	-
	K	38	J_t	kgcm ²	11.8	11.0	10.6	10.2	10.0	-	-	-	-	-	-	-	-	-	-	-
				10 ⁻³ in.lb.s ²	10.4	9.73	9.34	9.04	8.88	-	-	-	-	-	-	-	-	-	-	-

Please contact us for information on the best configuration for S1 conditions of use (continuous operation).

- ^{a)} Other ratios available on request
- ^{b)} Higher speeds are possible if the nominal torque is reduced
- ^{c)} For higher ambient temperatures, please reduce input speed
- ^{d)} Idling torques decrease during operation
- ^{e)} Refers to center of the output shaft or flange

All technical data for front output side applies.
Technical data for rearward output versions, see page 386.

HG+ 140 MF 1/2-stage

		1-stage					2-stage												
Ratio ^{a)}		<i>i</i>	3	4	5	7	10	12	16	20	25	28	35	40	50	70	100		
Max. acceleration torque (max. 1000 cycles per hour)	T_{2B}	Nm	300	300	300	250	210	300	300	300	300	300	300	300	300	250	210		
		in.lb	2655	2655	2655	2213	1859	2655	2655	2655	2655	2655	2655	2655	2655	2655	2213	1859	
Nominal output torque (with n_m)	T_{2N}	Nm	190	190	190	175	160	190	190	190	190	190	190	190	190	175	160		
		in.lb	1682	1682	1682	1549	1416	1682	1682	1682	1682	1682	1682	1682	1682	1682	1549	1416	
Emergency stop torque (permitted 1000 times during the service life of the gearhead)	T_{2Not}	Nm	400	500	500	450	400	500	500	500	500	500	500	500	500	450	400		
		in.lb	3540	4425	4425	3983	3540	4425	4425	4425	4425	4425	4425	4425	4425	4425	3983	3540	
Nominal input speed (with T_{2N} and 20°C ambient temperature) ^{b), c)}	n_{1N}	rpm	1900	2000	2200	2000	2000	2900	2900	2900	2900	2900	2900	2900	3200	3200	3900		
Max. continuous speed (with 20% T_{2N} and 20°C ambient temperature)	n_{1Ncym}	rpm	2500	2800	3100	2800	2800	4000	4000	4000	4000	4000	4000	4000	4200	4200	4200		
Max. input speed	n_{1Max}	rpm	4500	4500	4500	4500	4500	4500	4500	4500	4500	4500	4500	4500	4500	4500	4500		
Mean no load running torque (with $n_1=3000$ rpm and 20°C gearhead temperature) ^{d)}	$T_{01/2}$	Nm	7.7	5.7	5.0	8.3	6.1	1.5	1.0	0.8	0.6	0.6	0.4	0.4	0.3	0.3	0.3		
		in.lb	68	50	44	73	54	13.3	8.9	7.1	5.3	5.3	3.5	3.5	2.7	2.7	2.7		
Max. torsional backlash	j_t	arcmin	≤ 4																
Torsional rigidity	C_{t21}	Nm/arcmin	32	36	41	39	38	36	36	36	36	36	36	36	36	41	39	38	
		in.lb/arcmin	287	321	360	346	337	319	319	319	319	319	319	319	319	363	345	336	
Max. axial force ^{e)}	F_{2AMax}	N	9900																
		lb _f	2228																
Max. radial force ^{e)}	F_{2RMMax}	N	9500																
		lb _f	2138																
Max. tilting moment	M_{2KMMax}	Nm	1692																
		in.lb	14974																
Efficiency at full load	η	%	96					94											
Service life (For calculation, see the Chapter "Information")	L_h	h	> 20000																
Weight incl. standard adapter plate	<i>m</i>	kg	22.6					24											
		lb _m	50					53											
Operating noise (with $n_1=3000$ rpm no load)	L_{PA}	dB(A)	≤ 68																
Max. permitted housing temperature		°C	+90																
		F	194																
Ambient temperature		°C	0 to +40																
		F	32 to 104																
Lubrication			Lubricated for life																
Paint			Blue RAL 5002																
Direction of rotation			Motor and gearhead opposite directions																
Protection class			IP 65																
Moment of inertia (relates to the drive) Clamping hub diameter [mm]	G	24	J_1	kgcm ²	-	-	-	-	-	4.20	3.84	3.27	3.16	2.78	2.73	2.48	2.45	2.43	2.42
				10 ³ in.lb.in ²	-	-	-	-	-	3.71	3.40	2.90	2.80	2.46	2.41	2.20	2.17	2.15	2.14
	K	38	J_1	kgcm ²	25.0	19.1	16.3	14.1	12.8	11.1	10.7	10.2	10.1	9.69	9.64	9.39	9.37	9.34	9.33
				10 ³ in.lb.in ²	22.1	16.9	14.4	12.4	11.3	9.83	9.51	9.01	8.92	8.58	8.53	8.31	8.29	8.27	8.26

Please contact us for information on the best configuration for S1 conditions of use (continuous operation).

- ^{a)} Other ratios available on request
- ^{b)} Higher speeds are possible if the nominal torque is reduced
- ^{c)} For higher ambient temperatures, please reduce input speed
- ^{d)} Idling torques decrease during operation
- ^{e)} Refers to center of the output shaft or flange

All technical data for front output side applies.
Technical data for rearward output versions, see page 386.

View A

1-stage:

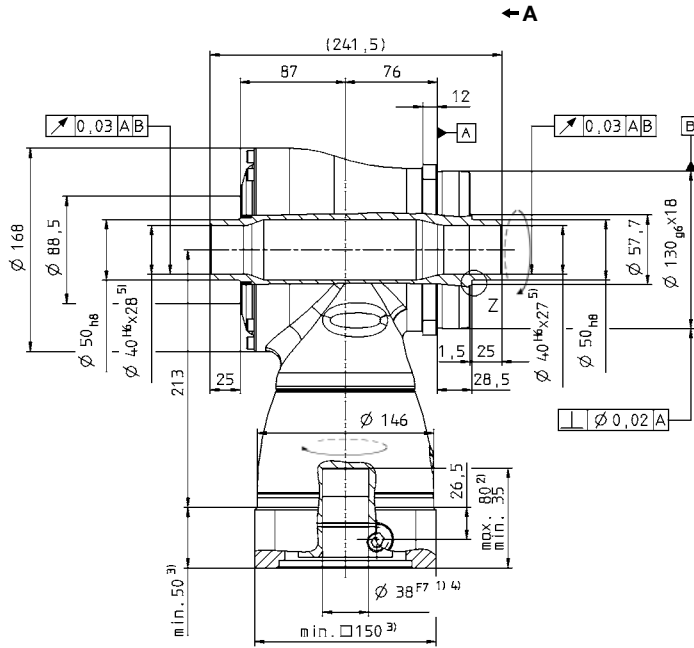
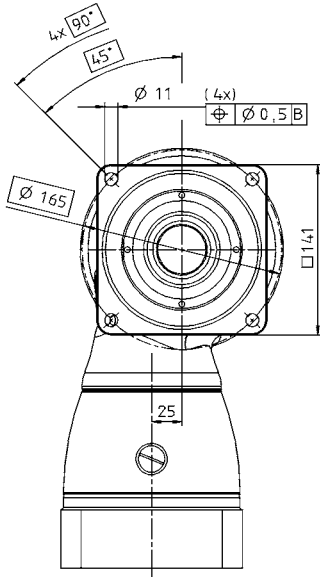

2-stage:

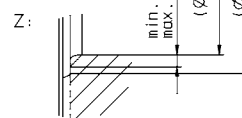
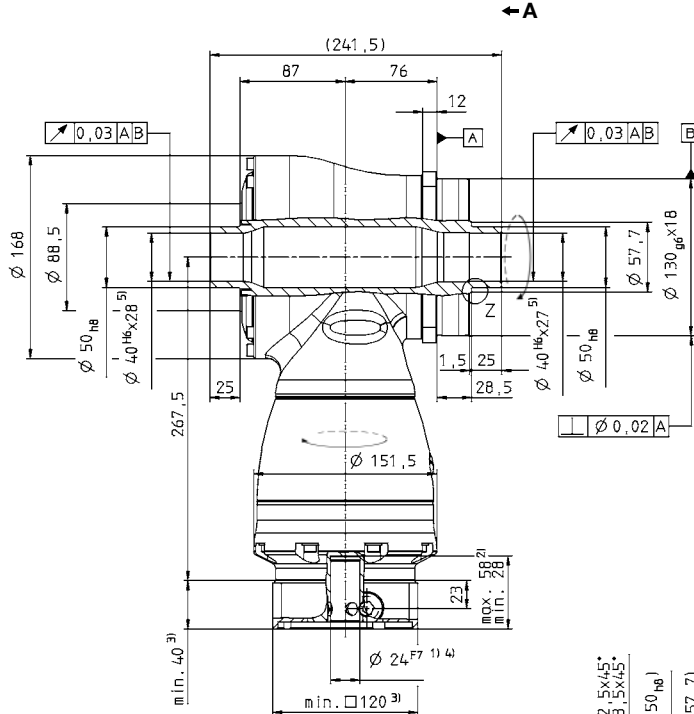
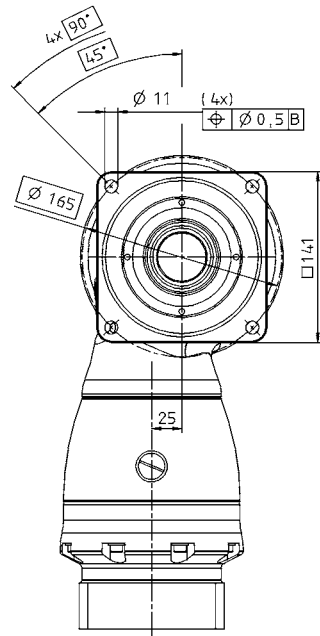

Alternatives: Single output shaft

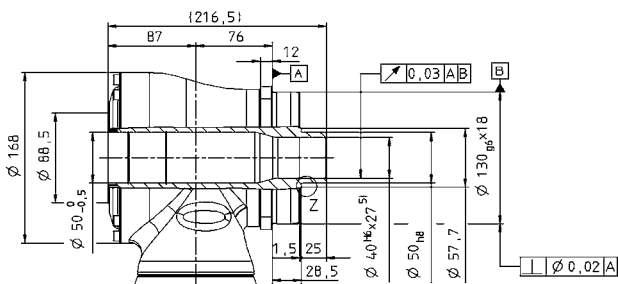

See technical data sheet for available clamping hub diameters (mass moment of inertia). Dimensions available on request.

Non-tolerated dimensions ± 1 mm

- 1) Check motor shaft fit.
- 2) Min./Max. permissible motor shaft length. Longer motor shafts are adaptable, please contact us.
- 3) The dimensions depend on the motor.
- 4) Smaller motor shaft diameter is compensated by a bushing with a minimum thickness of 1 mm.
- 5) Tolerance h6 for mounted shaft.

CAD data is available under www.wittenstein-alpha.com

Motor mounting according to operating manual

Right-angle gearheads
High End

HG+

HG+ 180 MF 1/2-stage

		1-stage					2-stage												
Ratio ^{a)}		<i>i</i>	3	4	5	7	10	12	16	20	25	28	35	40	50	70	100		
Max. acceleration torque (max. 1000 cycles per hour)	T_{2B}	Nm	640	640	640	550	470	640	640	640	640	640	640	640	640	550	470		
		in.lb	5664	5664	5664	4868	4160	5664	5664	5664	5664	5664	5664	5664	5664	5664	4868	4160	
Nominal output torque (with n_m)	T_{2N}	Nm	400	400	400	380	360	400	400	400	400	400	400	400	400	400	380	360	
		in.lb	3540	3540	3540	3363	3186	3540	3540	3540	3540	3540	3540	3540	3540	3540	3363	3186	
Emergency stop torque (permitted 1000 times during the service life of the gearhead)	T_{2Not}	Nm	900	1050	1050	970	900	1050	1050	1050	1050	1050	1050	1050	1050	1050	970	900	
		in.lb	7965	9293	9293	8585	7965	9293	9293	9293	9293	9293	9293	9293	9293	9293	8585	7965	
Nominal input speed (with T_{2N} and 20°C ambient temperature) ^{b), c)}	n_{1N}	rpm	1600	1800	2000	1800	1800	2700	2700	2700	2700	2700	2700	2700	2900	3200	3400		
Max. continuous speed (with 20% T_{2N} and 20°C ambient temperature)	n_{1Ncym}	rpm	2000	2400	2800	2500	2500	3500	3500	3500	3500	3500	3500	3500	3500	3800	3800		
Max. input speed	n_{1Max}	rpm	4000	4000	4000	4000	4000	4000	4000	4000	4000	4000	4000	4000	4000	4000	4000		
Mean no load running torque (with $n_1=3000$ rpm and 20°C gearhead temperature) ^{d)}	$T_{01/2}$	Nm	16.0	13.0	11.0	16.5	14.0	3.3	2.5	2.0	1.8	1.4	1.3	1.0	1.0	1.0	1.0		
		in.lb	142	115	97	146	124	29.2	22.1	17.7	15.9	12.4	11.5	8.9	8.9	8.9	8.9		
Max. torsional backlash	j_t	arcmin	≤ 4																
Torsional rigidity	C_{t21}	Nm/arcmin	71	80	91	89	88	80	80	80	80	80	80	80	80	91	89	88	
		in.lb/arcmin	633	711	803	791	780	708	708	708	708	708	708	708	708	805	788	779	
Max. axial force ^{e)}	F_{2AMax}	N	14200																
		lb _f	3195																
Max. radial force ^{e)}	F_{2RMax}	N	14700																
		lb _f	3308																
Max. tilting moment	M_{2KMMax}	Nm	3213																
		in.lb	28435																
Efficiency at full load	η	%	96				94												
Service life (For calculation, see the Chapter "Information")	L_h	h	> 20000																
Weight incl. standard adapter plate	<i>m</i>	kg	45.4				47												
		lb _m	100				104												
Operating noise (with $n_1=3000$ rpm no load)	L_{PA}	dB(A)	≤ 68																
Max. permitted housing temperature		°C	+90																
		F	194																
Ambient temperature		°C	0 to +40																
		F	32 to 104																
Lubrication			Lubricated for life																
Paint			Blue RAL 5002																
Direction of rotation			Motor and gearhead opposite directions																
Protection class			IP 65																
Moment of inertia (relates to the drive) Clamping hub diameter [mm]	K	38	J_1	kgcm ²	-	-	-	-	-	15.3	13.9	12.3	12.0	10.9	10.7	10.1	10.0	9.95	9.91
				10 ³ in.lb.in ²	-	-	-	-	-	13.5	12.3	10.9	10.6	9.65	9.48	8.96	8.88	8.80	8.77
	M	48	J_1	kgcm ²	73.3	51.6	42.1	34.0	29.7	30.0	28.7	27.0	26.7	25.6	25.4	24.8	24.7	24.7	24.6
				10 ³ in.lb.in ²	64.9	45.6	37.3	30.1	26.3	26.6	25.4	23.9	23.6	22.7	22.5	22.0	21.9	21.8	21.8

Please contact us for information on the best configuration for S1 conditions of use (continuous operation).

- ^{a)} Other ratios available on request
- ^{b)} Higher speeds are possible if the nominal torque is reduced
- ^{c)} For higher ambient temperatures, please reduce input speed
- ^{d)} Idling torques decrease during operation
- ^{e)} Refers to center of the output shaft or flange

All technical data for front output side applies.
Technical data for rearward output versions, see page 386.

View A

1-stage:

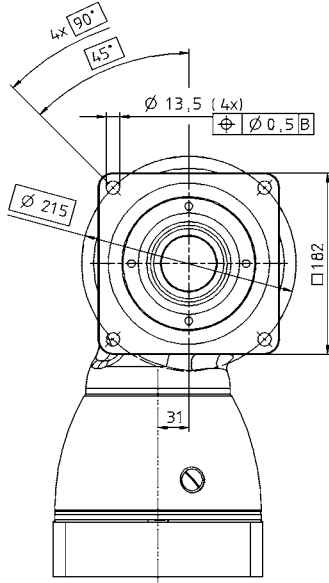

← A

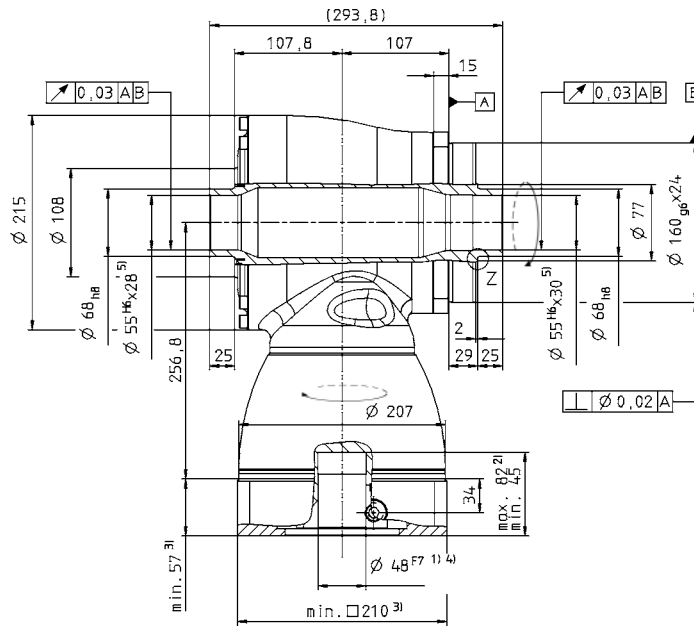

2-stage:

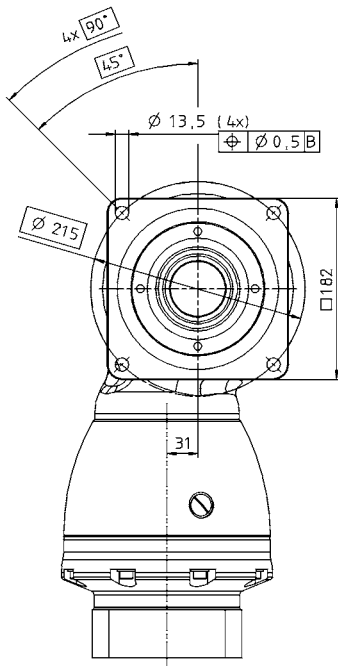

← A

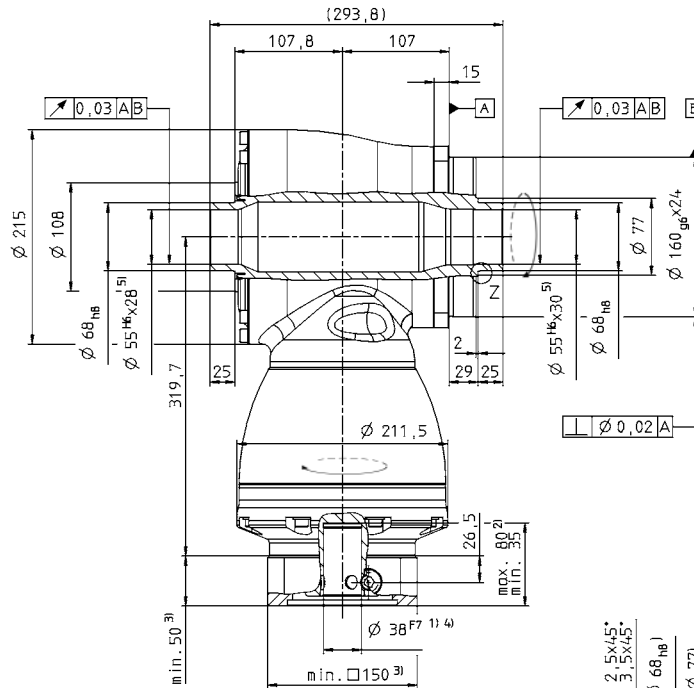

Z:

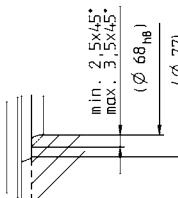

Alternatives: Single output shaft

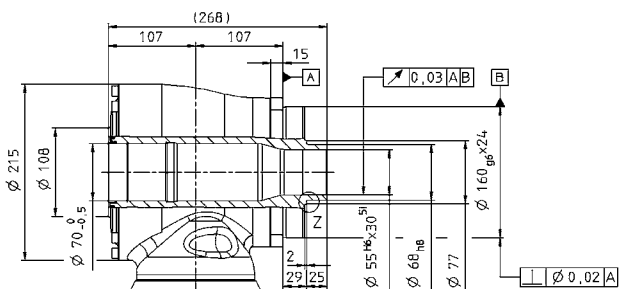

See technical data sheet for available clamping hub diameters (mass moment of inertia). Dimensions available on request.

Non-tolerated dimensions ±1 mm

- 1) Check motor shaft fit.
- 2) Min./Max. permissible motor shaft length. Longer motor shafts are adaptable, please contact us.
- 3) The dimensions depend on the motor.
- 4) Smaller motor shaft diameter is compensated by a bushing with a minimum thickness of 1 mm.
- 5) Tolerance h6 for mounted shaft.

CAD data is available under www.wittenstein-alpha.com

Motor mounting according to operating manual

Right-angle gearheads
High End

HG+